

## PGE Data Sheet (HT)

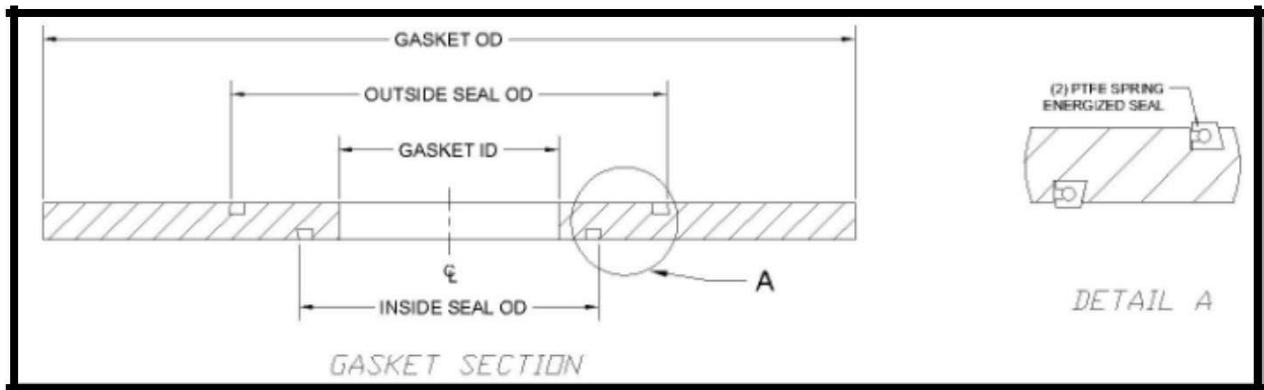

### Gasket Properties\*

**Carrier:** NEMA Grade G11

**Color:** Natural Tan (Tint may vary)

**Fluid Services:** Oil and Gas

**Maximum Operating Temperature (°F/°C):** 392°F/200°C

**Minimum Operating Temperature: (minus):** -50°F/ -45°C

**Maximum Pressure Class:** ASME 600#

### Typical Physical Properties\*

**Water Absorption (%)**: ASTM 0.09 Typical

### NEMA Grade G10 Mechanical Properties\*

**Tensile Strength (PSI)**: 41,000

(ASTM D638)

**Flexural Strength (PSI)**: 57,000

(ASTM D790)

**Flexural Modulus (Kpsi) LW/CW**: 2,900/ 2,600

(ASTM D790)

**Compressive Strength (PSI)**: 50,000

### Thermal Properties\*

**Coefficient of Linear Thermal**

**Expansion (thickness tested .125")** X-axis / Y-axis: 10.0 /

13.0 (IPC-TM 650-2.4.24)

**Flammability Rating**: Fire retardant

### Electrical Properties\*

**Dielectric Strength (V/mil)**: 550

### Isolation Kit Options:

**Seal Types**: Teflon (PTFE Spring Energized), O-Ring: Viton, Nitrile, EPDM

**Sleeves**: G11 only

**Washers**: G11, ZPS, Stainless Steel

**GRE Options**: G11

### Notes:

This is a general guide and should not be the sole means of selecting or rejecting this material. \* Values do not constitute specification Limits

†See GPT chemical resistance guide.

‡All isolation products are affected by exposure to heat and moisture where electrical isolation is concerned. Please note that field values may vary from test values due to exposure to one or both of these environmental factors.

**V1.3 - 04.2024**